

Issue	Change	Position	Date	Sign.
-------	--------	----------	------	-------

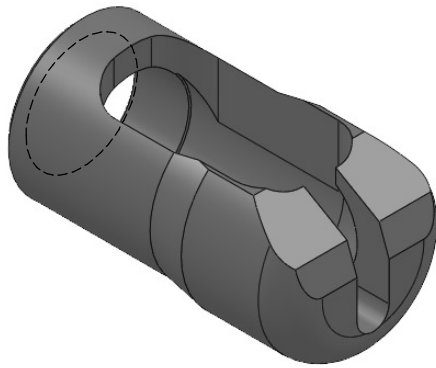
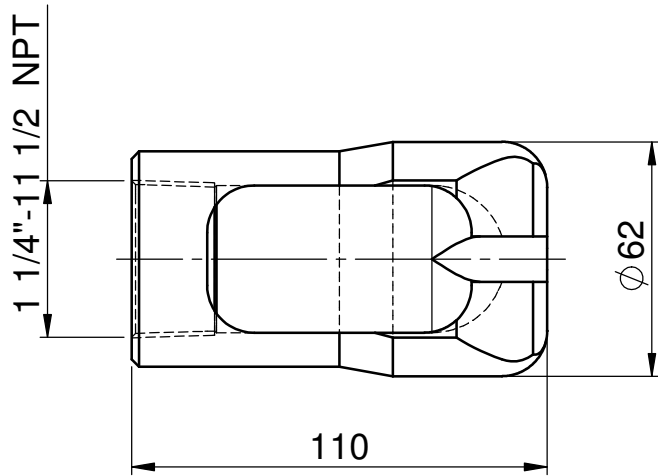
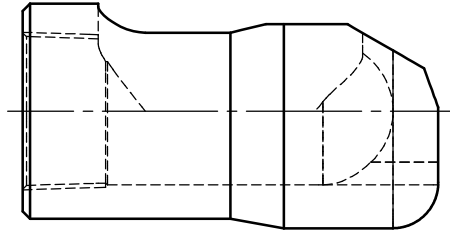
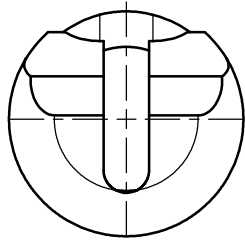

1,09 kg

DENNA RITNING ÄR REHOBOT AB:s EGENDOM. SKYDDAD ENLIGT GÄLLANDE LAG. THIS DRAWING IS THE PROPERTY OF REHOBOT AB. PROTECTED BY PREVAILING LAW.

Material		Blank, dimension		Heat treatment		Surface treatment	
Permissible deviations for dimensions without indication of tolerances						Surface roughness unless specified	
Machined parts		Castings		Fuse welded constr.		Ra μm ✓	
acc.SS-ISO-2768-1		acc.SS-ISO-8062		acc.SS-EN ISO 13920			
Designed by CS	Drawn by CS	Date 2021-06-14	Product TMK127 Chain attachment			Tol.system acc. ISO	
Prod.appr. Admin 2021-06-14	Design appr. DF 2021-06-14	Scale 1:2	Title Dimension drawing			Replaces D-28309	
			Dimension drawing			Replaced by	
						D-52349	

4

3

2

1